

APPROXIMATE PANEL CONFIGURATION

2' RAIL ASSEMBLY	1 GLASS PANEL
4' RAIL ASSEMBLY	1 GLASS PANEL
5' RAIL ASSEMBLY	2 GLASS PANELS
6' RAIL ASSEMBLY	2 GLASS PANELS
8' RAIL ASSEMBLY	3 GLASS PANELS
10' RAIL ASSEMBLY	3 GLASS PANELS

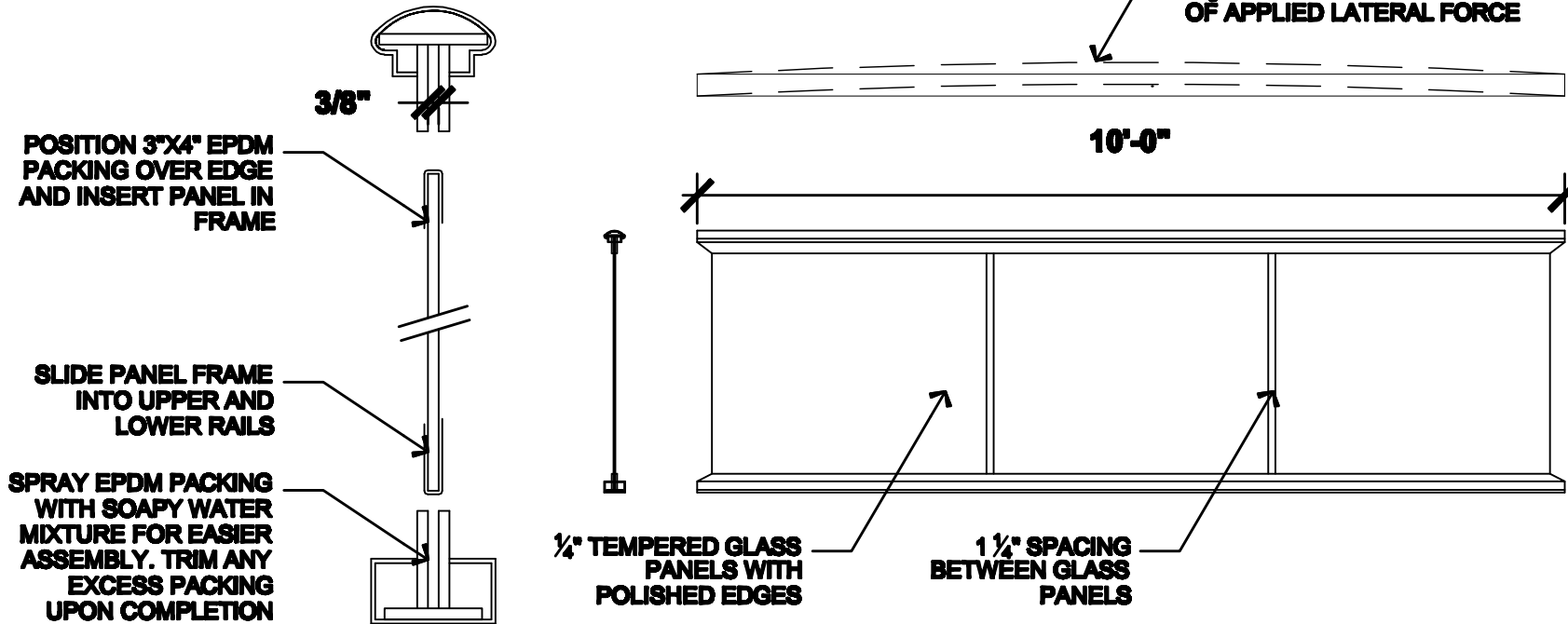

HURRICANE GLASS PANELS



THE EXACT DISTANCE BETWEEN POSTS MUST BE DETERMINED BEFORE RAIL ASSEMBLY CAN BE FABRICATED. ADD 3-5 DAYS DELIVERY WHEN GLASS IS SUPPLIED BY GLASRAIL

PROJECT DETAILS		FILE NO. 000-0-000	
4215-A Russell Road Mukilteo, WA. 98275		Fax 425-348-8476	
Main Office 425-348-3808			
GLASRAIL			
DRAWN CVH	APP'D		
SCALE 1/2" = 1'-0"	DATE 5/18/2010		
DR11		SHEET 11 OF 12	